

DATE
APRIL 16, 2004
CATALOG NO.
X0504

OUTLINE DIMENSIONS
3-PHASE INDUCTION MOTOR

MOTOR TYPE:
AEHHXU
FRAME NO. 326T

| Pole | HP | KW | Hz | VOLT | Syn. Speed RPM |
|------|----|------|----|---------|-------------------|
| 4 | 50 | 37.3 | 60 | 230/460 | 1800 |

| Ins | Rating | Dimension in | Approx Weight | Bearings | |
|-----|--------|--------------|---------------|----------|-----------|
| F | CONT. | inches | 781 lbs. | DE: 6312 | NDE: 6212 |

Totally Enclosed Fan-Cooled Type. Squirrel-Cage Rotor.

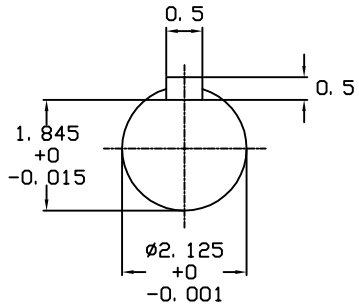
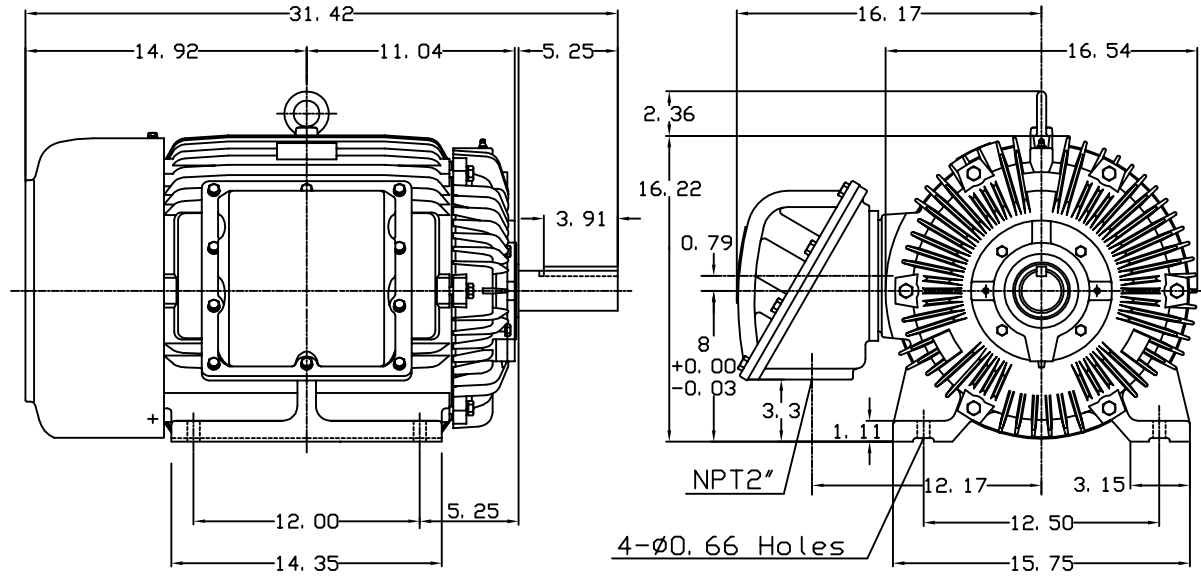

NOTE:
1. EXPLOSION-PROOF:
CLASS I GROUP D AND
CLASS II GROUP E,F,G.

① 03. 16. 00 J. C. LIN

| | | |
|-------|-------------|----------|
| DWN. | J. H. LIANG | 11-30-98 |
| CHKD. | C. H. KAO | 12-26-98 |
| APPD. | Y. B. HUANG | 12-26-98 |



DWG NO.
31049J739003