

Shaft Mount Gear Reducers by

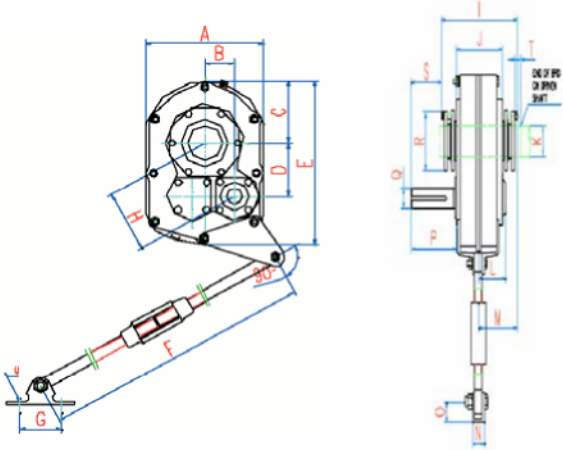

Speed Reducer and Motor Mount Dimensional Information



- Size 3** 1.25 Diameter Shaft; .25 x .13 x 2.88 Keyed Shaft
- Size 4** 1.44 Diameter Shaft; .38 x .19 x 4.06 Keyed Shaft
- Size 5** 1.94 Diameter Shaft; .50 x .25 x 4.50 Keyed Shaft
- Size 6** 2.19 Diameter Shaft; .50 x .25 x 4.50 Keyed Shaft

Reducer Dimensions

	3	4	5	6
A	9.25	10.38	13.13	15.13
B	2.33	2.76	3.04	4.09
C	4.84	5.50	6.56	7.56
D	4.17	4.79	5.67	6.73
E	12.88	15.13	18.31	21.31
F	26.94-32.94	29.19-35.19	29.19-35.19	29.19-35.19
G	3.00	4.00	4.00	4.75
H	4.78	5.53	6.43	7.88
I	9.22	9.98	10.52	11.53
J	5/8	3/4	3/4	3/4
K	2 3/16	2 7/16	2 15/16	3 7/16
L	3.30	3.14	4.45	4.57
M	4.52	4.79	5.05	5.73
N	1.25	1.44	1.44	2.75
O	1.06	1.75	1.75	2.00
P	4.34	5.57	5.74	6.08
R	4.38	4.81	5.63	6.13
S	2.34	3.44	3.44	3.73
T	1.50	1.75	1.81	1.81
U	0.44	0.50	0.50	0.63

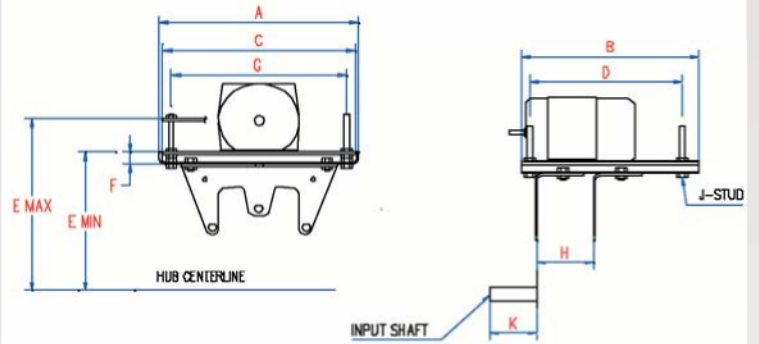

Motor Mount Dimensions

	3	4	5	6
A	14.63	18.63	18.63	20.50
B	11.00	17.00	17.00	18.50
C	13.50	17.50	17.50	19.25
D	9.25	14.25	14.25	16.50
E	11.59-15.78	11.96-16.73	12.53-17.28	14.56-19.31
F	1.62	1.78	1.84	1.84
G	12.00	15.50	15.50	17.50
H	4.25	4.63	4.13	4.50
J	5/8 x 7	3/4 x 8	3/4 x 8	3/4 x 8
K	4.88	6.13	6.65	7.31

Standard Bushing Kits

	1-15/16	2-3/16	2-7/16	2-15/16	3-7/16
Size 3	X	X			
Size 4		X	X		
Size 5			X	X	
Size 6				X	X